

# **2006 Tasar BC Championships**

September 9 and 10th

## **Metro Vancouver Tasar Fleet**

Jericho Sailing Centre, Vancouver, BC, Canada

### **Sailing Instructions**

#### 1 Rules

The regatta will be governed by The Racing Rules of Sailing (RRS), the prescriptions of the Canadian Yachting Association, the Class Rules of the World Tasar Class Association, except as any of these are changed by these sailing instructions or by the North American Tasar Association.

#### 1.1 The North American Tasar Association has changed the Tasar Class rules as follows:

Rule C.6 Crew Weight does not apply  
Rule F.1.3 (forestay length) does not apply.

#### 2 Entries

Entry is open to all Tasars conforming to the Class Rules of the World Tasar Class Association as changed by 1.1.

#### 3 Notices to Competitors

Notices to competitors will be posted on the official notice board located just inside the east entrance of the Jericho Sailing Centre building.

#### 4 Changes in Sailing Instructions

Any change to the sailing instructions will be posted on the day it will take effect at least 45 min prior to racing, except that any change to the schedule of races will be posted by 6 PM on the day before it will take effect.

#### 5 Signals Made Ashore

#### 5.1 Signals made ashore will be displayed from the flag staff at the main ramp at the Jericho Sailing Centre.

#### 5.2 Flag AP with two sound signals (one sound signal when lowered) means “The race is postponed. The warning signal will be made not less than 30 minutes after AP is lowered (on shore) or 1 min after the AP is lowered on the water.”

#### 6 Schedule of Races

The warning signal for the first race will be 12:30 PM on Saturday September 9th. The warning signal for the first race on Sunday, September 10th will be at 10:30 AM.

#### 7 The Course

The diagrams in Appendix A show the courses, including the approximate angles between legs, the order in which marks are to be passed, and the side on which each mark is to be left.

## Sailing Instructions - 2006 Tasar BC Championships

### 8 Marks

Marks will be yellow or orange tetrahedral (the color of the windward mark will be indicated at the skippers meeting).

### 9 The Start

#### 9.1 Races will be started according to RRS rule 26 as modified below.

5 min class flag up

4 min P flag (blue) up

1 min P flag (blue) down

Start class flag down

In the event of a general recall the 1<sup>st</sup> substitute will be lowered 1 min. before the class flag will be flown to start a new sequence. The I flag or the Black flag may be flown after a general recall.

#### 9.2 The starting line will be between an orange flag on the race committee boat at the starboard end and a pin with a red flag at the port end.

#### 9.3 A boat shall not start later than 6 minutes after her starting signal.

### 10 Change of Course After the Start

A change of course after the start will be signaled before the leading boat has begun the leg, although the new mark may not then be in position. Any mark to be rounded after rounding the new mark may be relocated to maintain the original course configuration. When in a subsequent change of course a new mark is replaced, it will be replaced with an original mark.

### 11 The Finish

The finishing line will be between an orange flag on the race committee boat at the port end and a pin with a blue flag at the starboard end.

### 12 Time Limit

The time limit for all races will be 90 min. Boats failing to finish within 30 minutes after the first boat finishes or within the time limit whichever is later, will be scored points one more than the position of the last boat to finish.. This changes rules 35 and A.4.2.

### 13 Protests

#### 13.1 Protests shall be written on forms available at the Jericho Sailing Centre office and delivered there within Protest Time which will begin when the race committee comes ashore after the last race of the day and end 60 minutes later.

#### 13.2 Protests will be heard in approximately the order of receipt as soon as possible.

#### 13.3 Protest notices will be posted within 30 minutes of the protest time limit to inform competitors where and when there is a hearing in which they are parties to a protest or named as witnesses.

## Sailing Instructions - 2006 Tasar BC Championships

### 14 Scoring

The Low Point scoring system, rule A2, will apply, modified so that each boat's series score will be the total of her race scores, with her worst score discarded if 5 or more races have been completed. Nine races are scheduled (although more may be sailed pending conditions), of which 2 races shall be completed to constitute a series.

### 15 Safety

15.1 A boat that sails between a tug and its tow will be disqualified.

15.2 When code flag "Y" is flown all crew must wear appropriate personal flotation at all times while afloat.

### 16 Prizes

Prize giving will be at the Jericho Sailing Centre as soon as possible after the completion of racing on Sunday September 10th.

17 The course used will be indicated by code flags flown from the committee boat.

Course 1 (White pennant with red circle) Standard Triangle Start- 1 - 2 - 3 - finish

Course 2 (Blue pennant with white circle) Windward - Leeward Start- 1 - 2 - finish

Course 3 (Red, white, and blue pennant) Bermudian Triangle Start -1 - 2 - 3 - 1 - 3 - finish

Course 4 (Red pennant with white cross) 2X Windward - Leeward Start- 1 - 2 - 1 - 2 - finish

For course 2 or 4, mark 2A may be used as shown to make a leeward gate. Boats must finish the downwind leg by sailing through the gate, and may round either gate mark to begin the next leg.

**See pg 5 for alternate courses with downwind finishes to be used if the committee boat is downwind of the leeward mark.** Leeward gates will not be used with these alternate courses

# Sailing Instructions - 2006 Tasar BC Championships

## Appendix A Courses.

Course 1. S - 1 - 2 - 3 - F

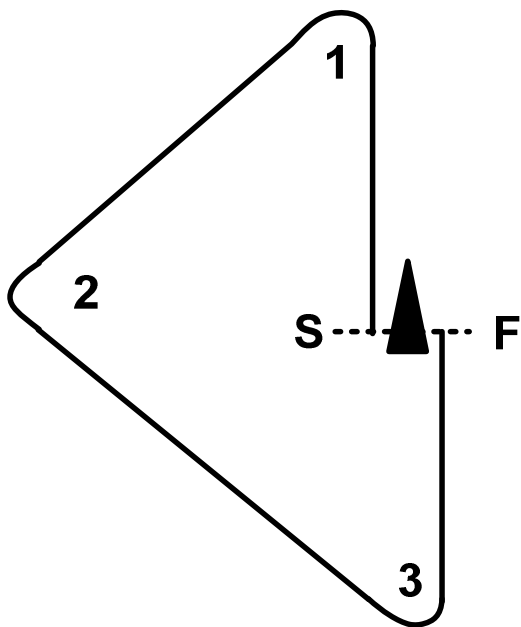

Course 2. S - 1 - 2 - F

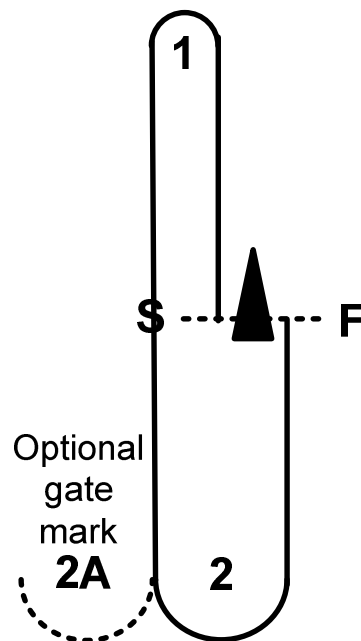

Course 3. S - 1 - 2 - 3 - 1 - 3 - F

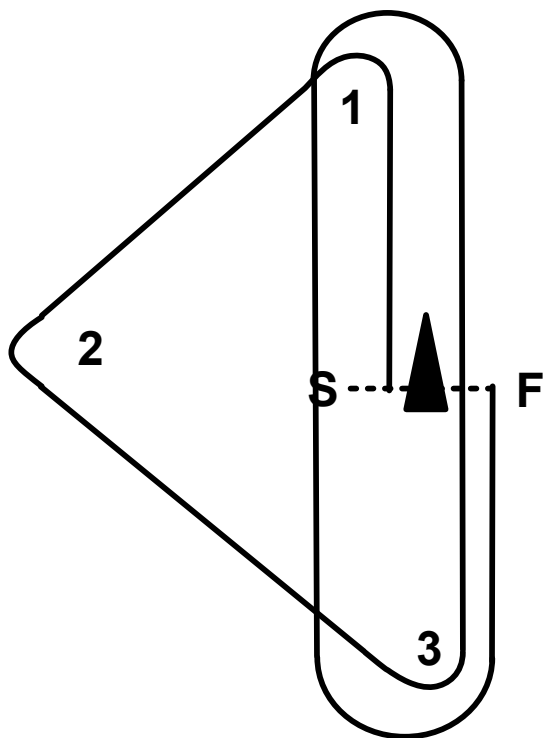

Course 4. S - 1 - 2 - 1 - 2 - F

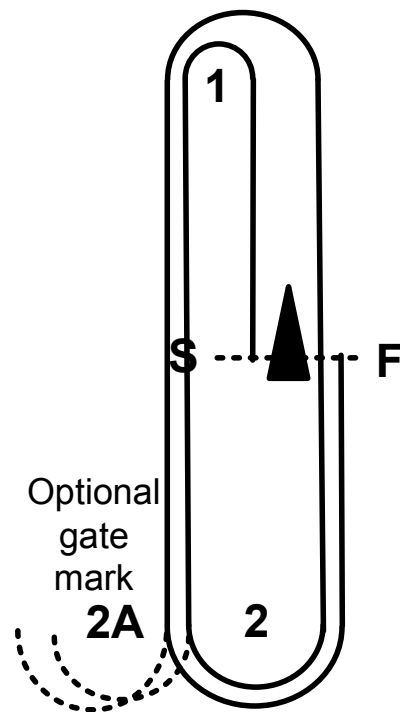

# Sailing Instructions - 2006 Tasar BC Championships

Alternate Courses, to be used if the committee boat is downwind of the leeward mark

Course 1. S - 1 - 2 - 3 - F

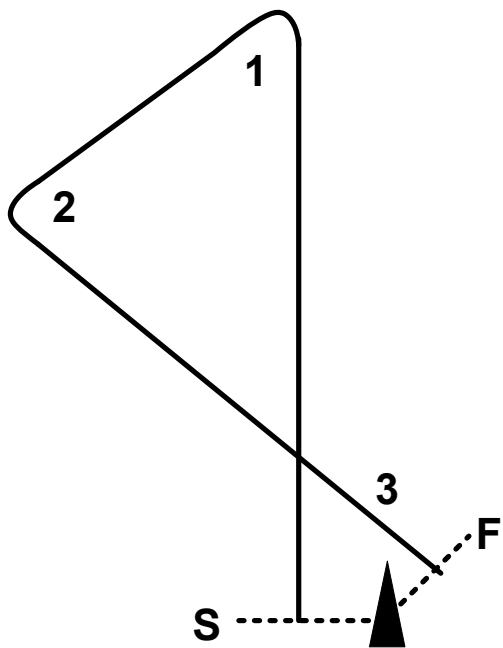

Course 2. S - 1 - 2 - F

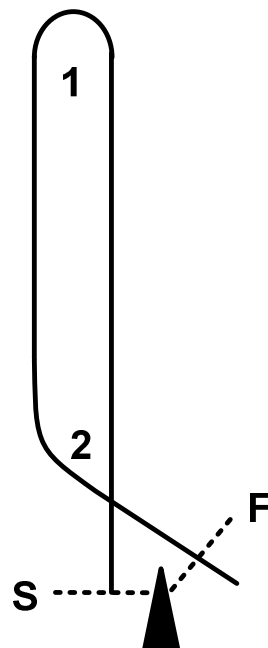

Course 3. S - 1 - 2 - 3 - 1 - 3 - F

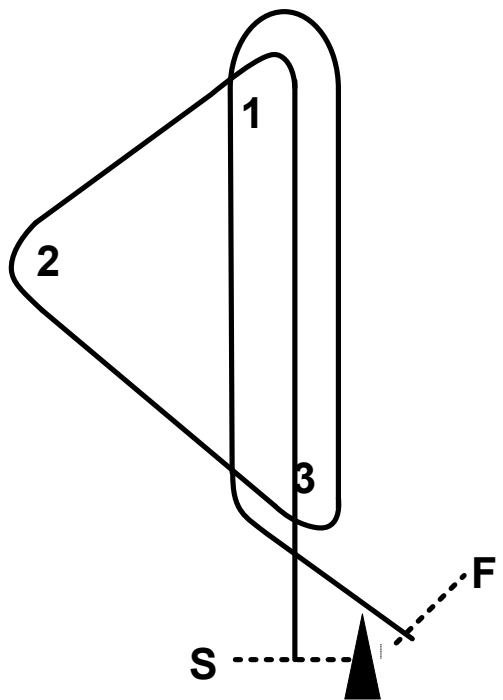

Course 4. S - 1 - 2 - 1 - 2 - F

